

Accurate temperature control in a reactor or mixing vessel is vital in any biotech or pharmaceutical process application. CPME GmbH have developed a modular Temperature Control Unit concept that has proven successful for its versatility, consistency and reliability.



FEATURES

- ✓ Compact, modular design - easy to transport and install.
- ✓ All piping, frame and main components in stainless steel.
- ✓ Plate & frame or shell & tube heat exchanger alternatives.
- ✓ Designed for either a heating or cooling duty.
- ✓ Air purge system for switchover between heating or cooling.
- ✓ Automatic water regulating system with divert valves.
- ✓ Fully automated with accurate PID control of product temperature.
- ✓ Safe, energy efficient, economical and environmentally friendly.
- ✓ 100% drainable with open design for easy maintenance.

OPTIONS

- Available in a wide range of models suitable for tanks from 200L – 15,000L and for temperature ranges from -15°C to 150°C.
- Suitable for water, brine, food safe glycol or other heat transfer fluids.
- Versions suitable for use in cleanrooms, outdoor use or ATEX environments.
- Interfaces with all type of plant utilities
- cGMP compliant standalone automation system or integrated with customer's production system.

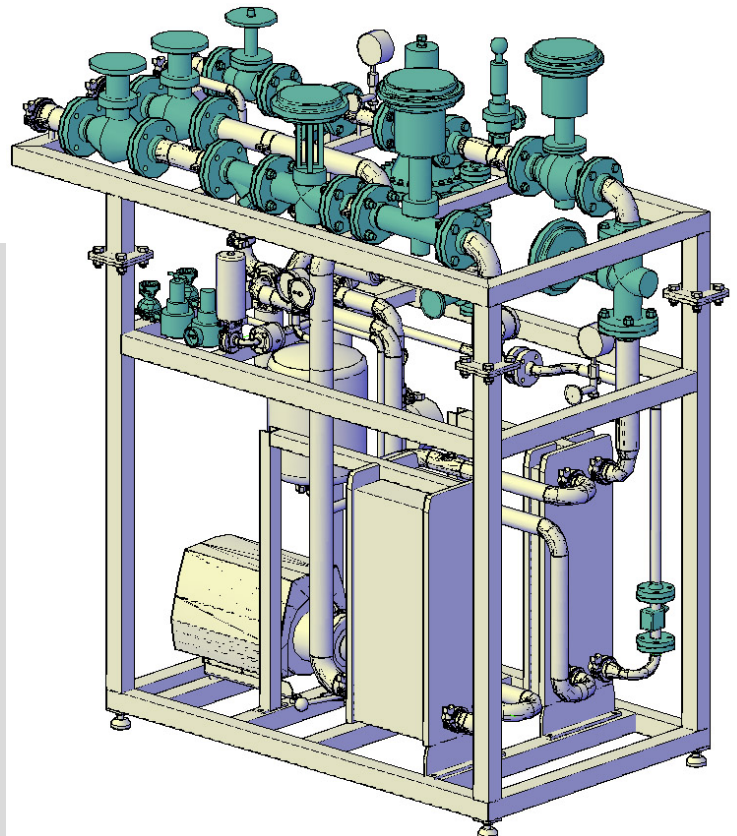

About Us

With its headquarters in southern Germany, CPME is a recently formed design, engineering and project management company delivering innovative solutions to the pharmaceutical and biotechnology sectors. Specializing in the turnkey provision of technically advanced and engineered solutions for the provision of process systems required in the production of a range of medicines including:

- Vaccines
- Antibiotics
- Injectibles, Infusions
- Oral preparations, solid dosage and suspensions
- General use drugs, creams and lotions

With offices currently in Germany, Beijing, Moscow and Hong Kong, CPME is uniquely positioned to leverage its wealth of predominantly European based expert knowledge along with an extensive network of trusted partners, in order to provide cost-effective solutions regionally and globally.

The background of the engineering resources of CPME does not directly originate from the pharmaceutical sector but from the dairy, drinks & food markets. This brings a broad range of experience to the company now balanced along with many further years of experience in the pharma and bio-tech sectors.

Furthermore, CPME offers in depth knowledge in topics such as construction, utility and electrical services, automation and control systems, building and infrastructure, clean room design and many more related subjects.

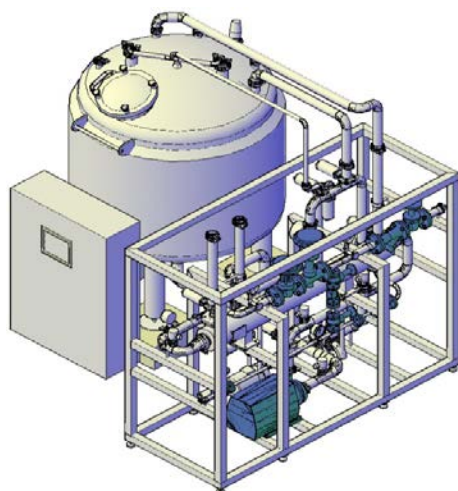

Services & Solutions

CPME can specifically provide services and solutions in both sterile and aseptic applications for the following:

- Media preparation and storage.
- Ingredient handling, blending and filtration.
- Fermenter and reactor systems.
- Final product treatment and storage.
- PW, WFI and PSG systems, storage and distribution.
- CIP, SIP and DIP.
- Utility provision, both clean and industrial (black).

CPME can offer our customers the following expertise:

- Conceptual, initial & detailed process design.
- Equipment & component specification and sourcing.
- On-site mechanical, electrical & control system supervision.
- Project management, from a single unit scope of supply up to complete turnkey solution provider.
- Process & project engineering as well as electrical & automation engineering.
- CAD resources, both in 2D & 3D.
- Validation & documentation support to EU Pharmacopeia, US FDA, CFDA (China) & PIC/s standards.
- All services delivered in accordance with our own high standards of GEP (Good Engineering Practice) & to all cGMP & cGAMP regulations.

GERMANY OFFICE
CPME GmbH
 Wuerzburger Strasse 7
 86720 Noerdlingen,
 Germany
 T +49 9081 29010 30
 F +49 9081 29010 50
 E info@cpme-gmbh.com

CHINA OFFICE
CPME China
 7A, Tower B, Wangjing Building,
 Zhong Huan Nan lu 9,
 Chaoyang District, Beijing, PR of China
 T +86 10 84729972/3
 F +86 10 84729973-111
 E info@cpme-gmbh.cn

HONG KONG OFFICE
CPME Asia Pacific
 C6, 11/F, Tak Wing Ind. Bldg.
 3 Tsun Wen Rd, Tuen Mun,
 Hong Kong
 T +852 3689 8991
 F +852 3689 8992
 E info@cpme-gmbh.com

RUSSIA OFFICE
CPME CIS & Russia
 Bibirevskaya Street 17B
 127549 Moscow,
 Russia
 T +7 499 653 76 43
 F +7 499 653 76 43
 E info@cpme-gmbh.com