

CUSTOMER'S ISSUE

This customer needed an innovative solution to fit four complete process compounding and storage systems, including CIP, into a reduced space.

Objectives:

- Eliminate the need for platforms to reach vessel manways in order to add ingredients.
- Innovative design to optimize cleanroom space.

CPME SOLUTION

Description of the CPME solution:

- ✓ Components in "modular skid" units.
- ✓ Low shear blending system mounted at ground level.
- ✓ Custom made vessels with optimized geometry.

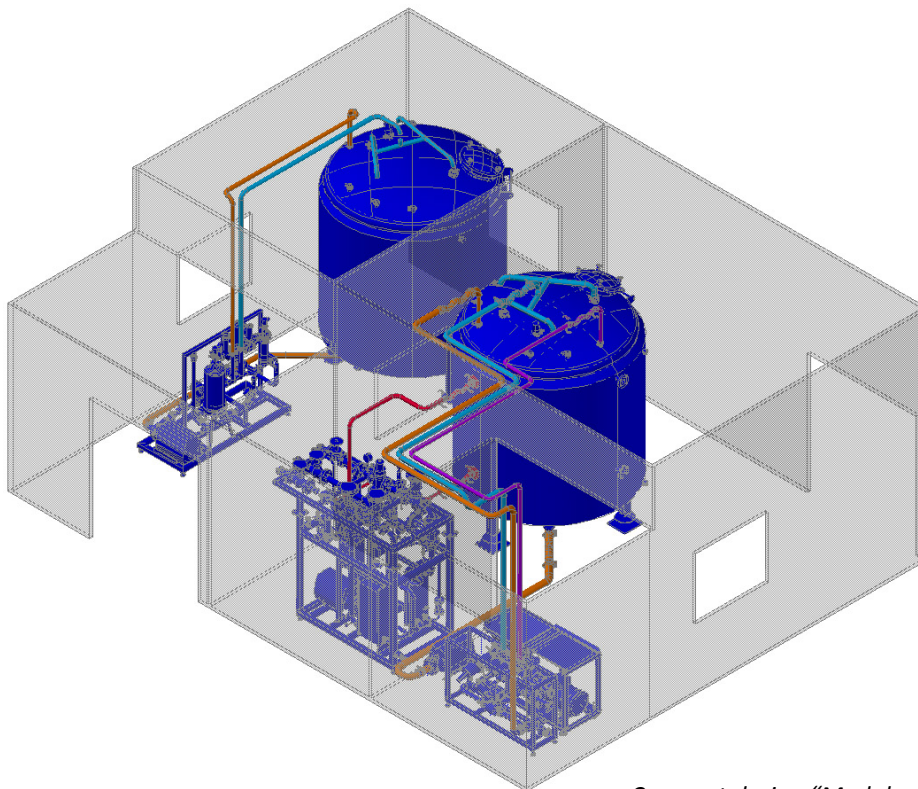
Components in "Modular Skid" units.

Compact design "Modular Skid" units optimized for space and simplified installation.

Low shear blending system mounted at ground level.



The ergonomically designed hopper eliminates the need for platforms to feed ingredients into the vessel using the manway.

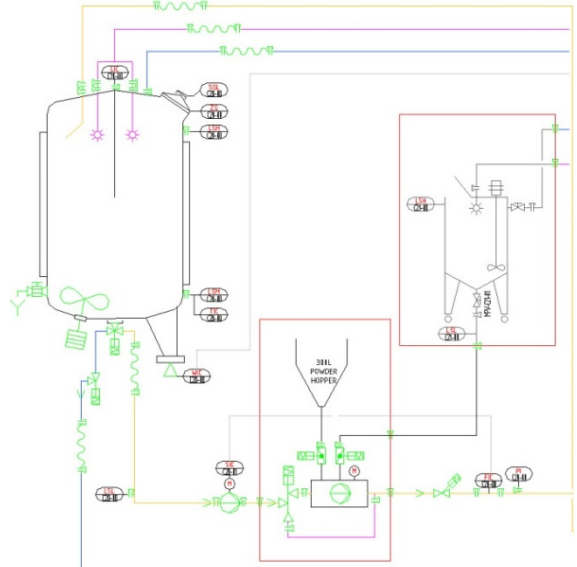

The design allows not only the addition of powder but also pre-mixed solution by means of a second connection into the blender intake.

Mixing vessel with integrated blending and oxygen removal.



Vessels custom designed for low ceiling cleanrooms.